



MAXIBLUE®

De MaxiBlue® werd speciaal ontwikkeld om hogere debieten aan te kunnen. Doordat de MaxiBlue® grotere capaciteiten en aanzuig aankan is dit systeem volledig aangepast aan airconditioners van 14 kW.

- Uitermate geschikt voor de meest complexe installaties
- De pomp werkt enkel als er condenswater is
- Energiezuinig systeem



Debiet	14 L/h max.
Verticale opvoerhoogte	8 m max.
Decibels	21 dB
Aanzuighoogte	8 m
Afmetingen	67x158x58 mm (LxBxH)

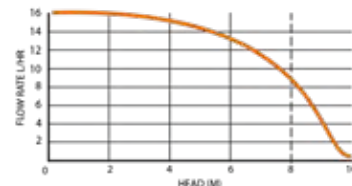

Sensor



Reservoir



Drainstick

Art. nr.	Omschrijving	Alarmtype	St/doos
BLD-2020	MaxiBlue® pomp met sensor (L=2m)	-	1
BLD-2100	MaxiBlue® pomp met reservoir	FSA	1
BLD-2030	MaxiBlue® pomp met drainstick	FSA	1



V (VERTICAL)	H (HORIZONTAL)
8 M	0 M
7 M	3 M
6 M	6 M
5 M	9 M
4 M	12 M
3 M	15 M
2 M	18 M
1 M	21 M

MEGABLUE®

De MegaBlue® is een industriële pomp die uiterst geschikt is voor installaties waar een grote afstand moet overbrugd worden.

- De pomp kan grote debieten aan
- Tolereert kleine deeltjes in het water
- Geen onderhoud nodig
- Kan droog draaien zonder dat er kans is op oververhitting van de pomp

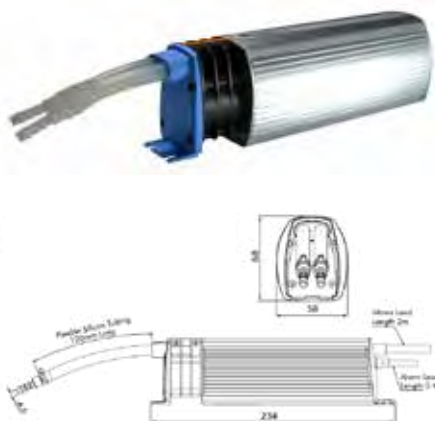

Debiet	50 L/h max.
Verticale opvoerhoogte	20 m max.
Decibels	23 dB
Aanzuighoogte	7 m
Afmetingen	64x276x51 mm (LxBxH)

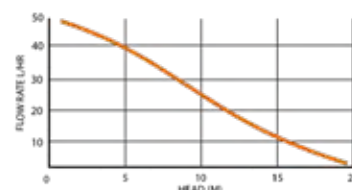

Sensor



Reservoir



Drainstick

Art. nr.	Omschrijving	Alarmtype	St/doos
BLD-3020	MegaBlue® pomp met sensor (L=2m)	-	1
BLD-3100	MegaBlue® pomp met reservoir	FSA	1
BLD-3030	MegaBlue® pomp met drainstick	FSA	1



V (VERTICAL)	H (HORIZONTAL)
20 M	0 M
15 M	15 M
10 M	30 M
5 M	45 M
0 M	60 M